



HELI

Hand Pallet Truck

5,500 lbs. Capacity

The Heli hand pallet truck is consistently reliable. With a load capacity of 5,500 lbs., it is the ideal hand pallet truck for most material handling needs.

Frame & Forks

- The frame and forks of the Heli hand pallet truck are of a welded steel structure, with heavy reinforcement at high load point areas.
- The fork ends are rounded and tapered to minimize damage at pallet entry and exit.
- Pallet entry and exit rollers allow easy pallet entry and exit with minimum damage.
- For ease of maintenance and lubrication, there is easy access to all bearing points.



Drawbar and Control Handle

- The closed loop design control handle is manufactured from steel for extra strength. The drawbar gives perfect control and protection for the operator's hands in restricted areas. The covered handle ensures positive control in all environments.
- The hydraulic hand control has three positions: lift, lower and neutral, to provide precise load control.
- The control handle allows for easy lowering pumping effort.



Hydraulics

- Heavy duty design with chrome-plated pistons with overload safety device.
- Even lowering of load is ensured by the load lowering valve.
- Heli pallet jack is designed for easy maintenance. Easy access to replace and service hydraulic unit.

General

- Totally enclosed bearings guard against failure from dust and prolongs service life.
- Steel drawbar with protected handle for safety and strength.
- Pivot mounted large polyurethane steer wheels ensure stability on uneven surfaces.
- 210° steer handle arc enables easy maneuvering of pallet truck in confined areas.
- Large polyurethane wheels for long life and improved stability. It is also quiet rolling and protects floors.



Description

Pump Unit

- Fully enclosed pump seals out dirt and moisture, preventing damage to seals.
- Chrome-plated ram and piston with high quality polyurethane seals to ensure performance.

Control Handle

- Low pumping effort
- Wide grip handle
- Hand control has three settings: lift, lower and neutral, to provide precise load control
- Highly maneuverable 202° steering for ease in tight quarters.

Wheels and Bearings

- Premium high quality polyurethane steer and load wheels provide superior rolling qualities yet resist chunking and cracking. All wheels fitted with sealed, lubricated precision bearings for ease of rolling and low maintenance.

General Data

ASME

- Standard truck meets all applicable mandatory requirements of Part II – ASME B56.10 Safety Standard for Manual Industrial Trucks.

For Your Safety

- Do not operate the Heli hand pallet truck unless you have been trained and authorized. Read all warnings and instructions before operating the hand pallet truck.
- Do not operate the Heli hand pallet truck until you have checked its condition. Give special attention to the wheels, handle, forks, lift and lower controls. Do not operate a damaged or faulty truck.
- Do not attempt repairs unless you are trained and authorized.
- Operate Heli hand pallet truck only from the designated operating position. Never place any part of your body on the lifting mechanism or under the forks or load.
- Do not carry passengers on the hand pallet truck.
- Do not handle unstable or loosely stacked loads. Use special care when handling long, high or wide loads to avoid losing the load, striking bystanders, or tipping the truck.
- Do not overload the truck. Check capacity plate for carrying capacity information. Overloading may cause truck to perform incorrectly.
- The capacity of the truck assumes an evenly-distributed load with the center of the load being at the halfway point of the length of the forks.
- Make sure that the length of the forks match the length of the pallet. Using a pallet truck where the forks are longer than the pallet will damage the truck if the pallet truck is pushed through the pallet and the forks are under a second pallet behind the one being lifted. When lowering the load, make sure the area where the pallet is to be placed is clear.

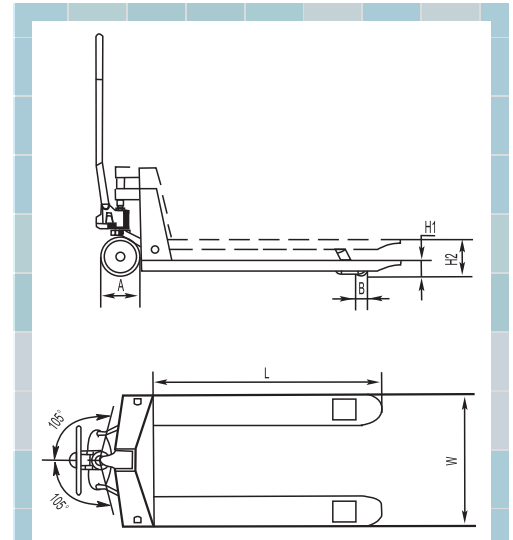

Technical Data

Load capacity:	5,500 lbs.
Lift (H2):	7.7"
Lowered height (H1):	2.9"
Steer wheels (A):	7.1" x 2.0"
Load wheels (B):	2.9" x 3.7"
Fork length (L):	48"
Fork width (W):	27"
Total weight:	202 lbs.



**Southwest
Equipment
Sales**

4105 Globeville Road
Denver, CO 80216
1-888-NEW-HELI (639-4354)
Fax: 303-293-0229
www.HeliForkliftUSA.com